



ThyssenKrupp Elevator
Manufacturing Spain

ALTUS

Cable Lift Without Machine Room

Technical Description



Cable Lift Without Machine Room

INDEX

1. Introduction
2. Models
3. Technical Data
4. Gear System
5. Control and Drive
6. Car Doors and Landing Doors
7. Car Desing
8. Indicators and Pushing-buttons



1. Introduction

Altus is a traction lift without machine room with a 1:1 rope suspension. The system uses a machine located in the shaft head. A bedplate fixed to both car and counterweight guides supports the machine and the speed governor.

The car and counterweight guides are fastened to only one shaft wall. Reactions are transferred to that wall and to shaft pit.

The control and the emergency rescue device are located in a cabinet placed next to the landing door of the upper stop. The control cabinet is accessible from the corridor.

With this simple, straightforward solution, there is no need of constructing a conventional machine room. The advantages are clear: more space available in a building and lower construction costs. It also provides more flexibility in architectural design.

Altus has been specially designed for the residential segment: private villas and low-mid height residential buildings. It can be also installed in nursing houses, small offices and hotels. Its use includes new installations as well as modernizations.

Altus complies with the safety requirements of EN-981-1 and the European Directive 95/16/EC. Deviations to the fact that there is no machine room have been taken into account.



2. Models

There are two versions of Altus Lift:

- **Altus Prima**, with a geared machine
- **Altus Supra**, with a gearless machine



3. Technical Data

- **Capacity:** 320 kg (4 persons)
450 kg (6 persons)
630 kg (8 persons)
- **Speed :** 1.0 m/s
- **Maximum travel height:** 45 m. (depending on total weight of car)
- **Maximum number of stops:** 12
- **Entrances :** One or double at 90° - 180°
(double entrances not allowed for 320 kg)
- **Gear unit :** W123 or W143 for Altus Prima
SincroSpeed for Altus Supra
- **Rope suspension :** 1:1
- **Drive :** VVVF Frequency Converter (Optional for Altur Prima)
- **Control :** CMC3
- **Car :** Millenium
Boreal for special applications.
Glass cabin (only 450 kg. in Altus Prima)
- **Doors type:** P-91 - 2 sheets telescopic sliding doors
C-91 - 2 sheets central opening doors
- **Doors width:** 700 mm. (320 kg)
800 mm. (450 kg)
900 mm. (630 kg)
- **Doors height :** 2000 mm.



4. Gear System

Several types of machines are used with Altus: Altus Prima: W 123V and W143V; Altus Supra: SincroSpeed

4.1. Altus Prima: Models W 123V and W143V

Their use and their limitation in a particular lift depends on the total weight of car (P+Q).

Generally, next table can be applicable:

Capacity	Machine	Maximum car weight (P+Q)
320 kg	W123V	1100 kg
450 kg	W123V for standard cars W143V for heavy cars	1325 kg 1575 kg
630 kg	W143V	1575 kg

(P+Q) includes the nominal capacity plus the weight of cabin. To estimate that weight the following items must be taken into account:

- Double entrances
- Marble or granite flooring
- Mirrors
- Doors
- Walls decorations
- Compensation chain (for travel heights higher than 30 m, a compensation chain must be included. The weight of this chain must be added).

Example: The reason why a 630 kg. panoramic cabin is not possible is due to (P+Q) weight, higher than 1575 kg.

4.1.1. Machine W123V

Specifications	Values
Weight:	240 to 260 kg.
Maximum shaft load	2750 kg.
Rated torque (1:36)	74 kgm.
Efficiency	0,8 (2:50)
Sound level at 1m. distance	56 dBA.
Maximum travel height	45 m.





W123V Technical Data

Capacity	Speed	Rope Susp.	Gear ratio	Power	Conect. /hour	R.P.M.	Traction Sheave	Cables		Voltage	Frequency (*)
kg	m/s			kW	40% E.D.		mm	Nº	mm	V	Hz
Two Speeds (1.0 / 0.25)											
320	1,00	1:1	2:50	5	90	1500/375	320	6	8	400	50
450	1,00	1:1	2:50	5	90	1500/375	320	6	8	400	50
Frequency Converter (VVVF)											
320	1,00	1:1	2:50	5,5	180	1500	320	6	8	400	50
450	1,00	1:1	2:50	5,5	180	1500	320	6	8	400	50

(*) 60 Hz available upon request

4.1.2. Machine W143V

Specifications	Values
Weight:	305 to 335 kg.
Maximum shaft load	2900 kg.
Rated torque (1:36)	123 kgm.
Efficiency	0,75 (2:50)
Sound level at 1m. distance	60 dBA.
Maximum travel height	45 m.
Maximum travel height	45 m.

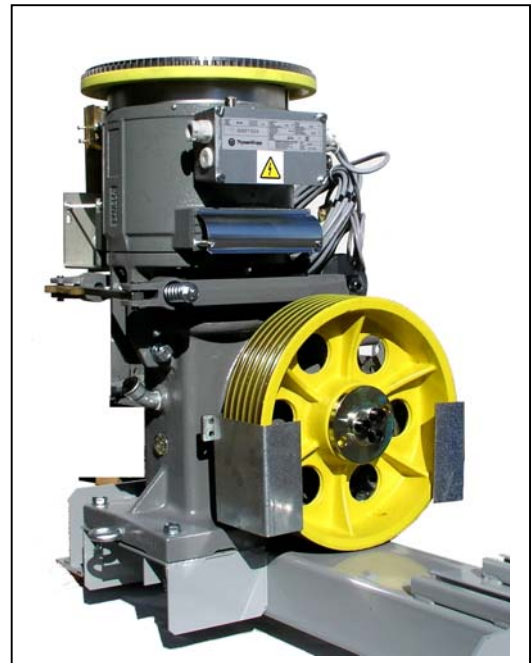

W143V Technical Data												
Capacity	Speed	Rope Susp.	Gear ratio	Power	Conect. /hour	R.P.M.	Encoder	Traction Sheave	Cables		Voltage	Frequency (*)
kg	m/s			kW	40% E.D.			mm	Nº	mm	V	Hz
Two Speeds (1.0 / 0.25)												
630	1,00	1:1	1:31	6.7	120	1500/375	NO	400	6	10	400	50
Frequency Converter (VVVF)												
630	1,00	1:1	1:31	8.0	180	1500	Yes/No	400	6	10	400	50

(*) 60 Hz available upon request



4.1.3. Machine bedplate

The machine is located in the shaft head, supported in a bedplate fixed to car and counterweight guide rails.

The bedplate is made with two beams. To minimise the transmission of vibrations and noise produced by the machine, rubber blocks are inserted between the bedplate and the guide rails.

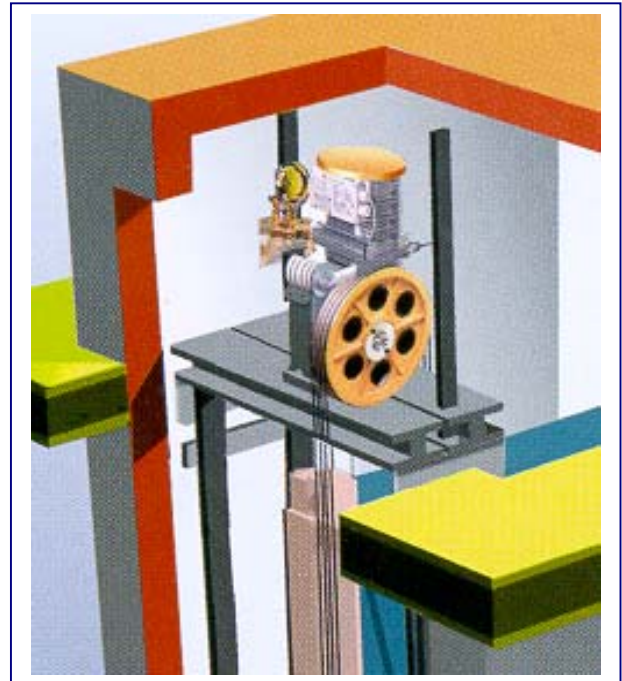

For special installations, another version of bedplate is available. In this version, the bedplate is placed in recesses made in the walls. And the reactions are transmitted to the shaft walls.

With that system, the machine transmits less vibrations and becomes less noisy

For maintenance purposes, access to the machine is done through the landing door on the upper stop.

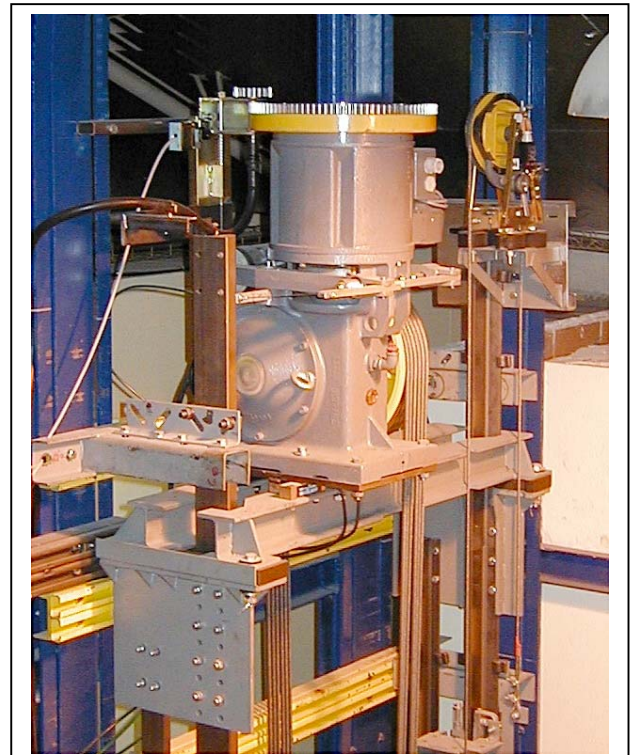



4.2 SincroSpeed



SincroSpeed Technical Data

Capacity kg	Speed m/s	Rope Susp.	P+Q (max)	Power kW	Conect. /hour 40% E.D.	R.P.M.	Traction Sheave mm	Cables		Voltage V	Frequency (* Hz
								Nº	mm		
Speed 1.0 m/s with Frequency Converter (VVVF)											
320	1,00	1:1	1325	3.2	180	1500	320	4	8	400	50
450	1,00	1:1	1325	3.2	180	1500	320	4	8	400	50
630	1,00	1:1	1575	4.3	180	1500	320	8	8	400	50

(*) 60 Hz available upon request

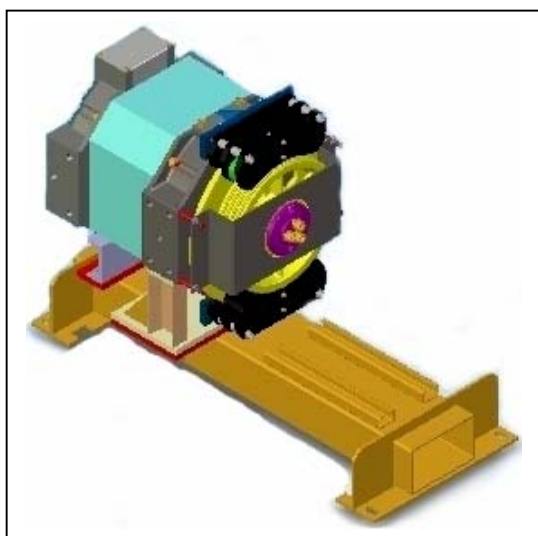

BedPlate for SincroSpeed



5. Control and Drive

The control used with Altus is the CMC3 series, a full microprocessor down collective control with the following commands:

- Overload
- Door-open, door-close
- Alarm
- Intercom
- Fireman key switch
- Call acceptance.

The control cabinet must be located next to the landing door of the upper stop. It also contains the emergency rescue device and, if this is the case, the frequency converter.

There is not possibility of changing the location of the cabinet, as there must be a visual contact of the machine from the cabinet.

Option: VVVF drive for Altus Prima





6. Car Doors and Landing Doors

5.1 Landing Doors

The standard doors for Altus Prima are the **P-91** series manufactured by TKEMS. P-91 are automatic sliding doors

Types:

- Standard : 2 steel sheets side opening, left or right
- Optional : 2 steel sheets central Opening.
(3 sheets doors are not available)

Dimensions: Three versions of doors width are available:

Load Capacity	Width	Height
320 kg	700 mm.	2000 mm.
450 kg	800 mm.	2000 mm.
630 kg	900 mm.	2000 mm.



Finishes:

Standard: Grey colour primed coating. The final coating must be done on site.

Optional: Stainless Steel SB grain 220

All the door posts have a box to assemble the landing operating panel, even in the case of multiple banks.

Fire Rate: The fire rating of the P-91 doors is PF-60, Spanish Certification

5.2 Car doors

The car doors are the automatic sliding **C-91** series. The door operator is a VVVF drive (VF-01-AT).

Finishes: Both doors and car front panel are made on Stainless Steel SB grain 220.

The car doors have a photocell safety device.



7. Car Design

Millenium is the standard cabin for Altus Prima. The main features of Millenium are:

- **Horizontal Car Operating panel:** Specially designed for the handicapped
- **Indirect lighting:** from a panel located in the upper part of the wall opposite to car operating panel wall.
- **Easy assembly on shaft:** The cabin is assembled from inside for only one person and in a few hours.

Models:

1. **Millenium Classic**, based on horizontal panels.
2. **Millenium Nova**, based on vertical panels.

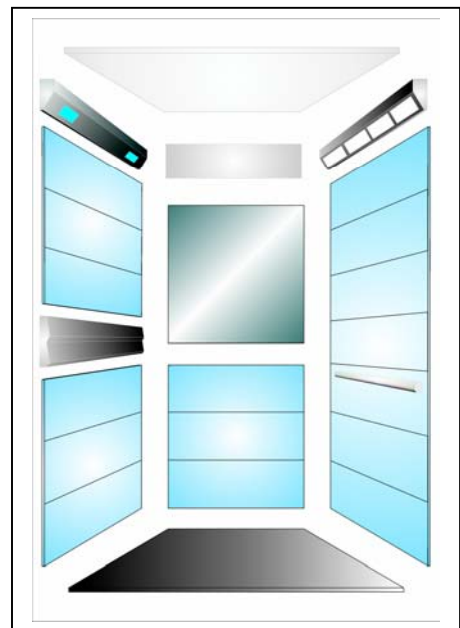



8. Indicators and Pushing Buttons



Information Module

	Indicador de posición	Pasillo
ESTANDAR	 Indicador LCD	
OPCIONAL	 Indicador programable LCD TB	